

SHAD

DUCATI MULTISTRADA 950/950S/1200/1260 '16-'21 D0ML98IF

3P
SYSTEM

DESIGNED IN
BARCELONA

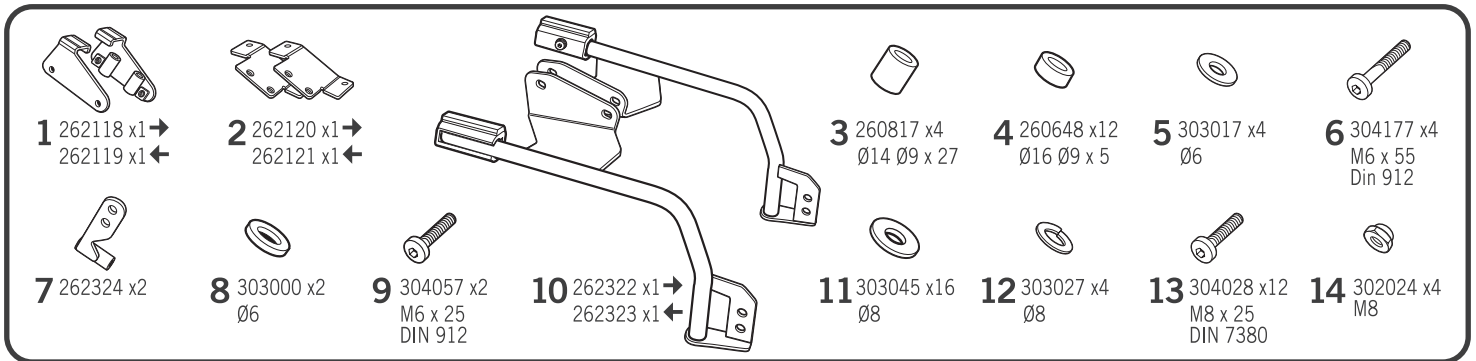

! WARNING!

GB Do not fully tighten the screws until it is ensured that the KIT is correctly attached and aligned.

E No apretar los tornillos del todo hasta asegurarse que el KIT está correctamente colocado y alineado.

D Ziehen Sie die Schrauben nicht ganz fest, bevor Sie sich nicht vergewissert haben, daß der Bausatz korrekt eingestellt und ausgerichtet ist.

I Non stringere del tutto le viti fin tanto non si è sicuri che il kit è collocato correttamente e allineato.

F Ne pas serrer les vis avant d'être sûr que le KIT soit correctement positionné et ajusté.

ATTENTION: For a full equip assembly, mount the 3p system after the top master.

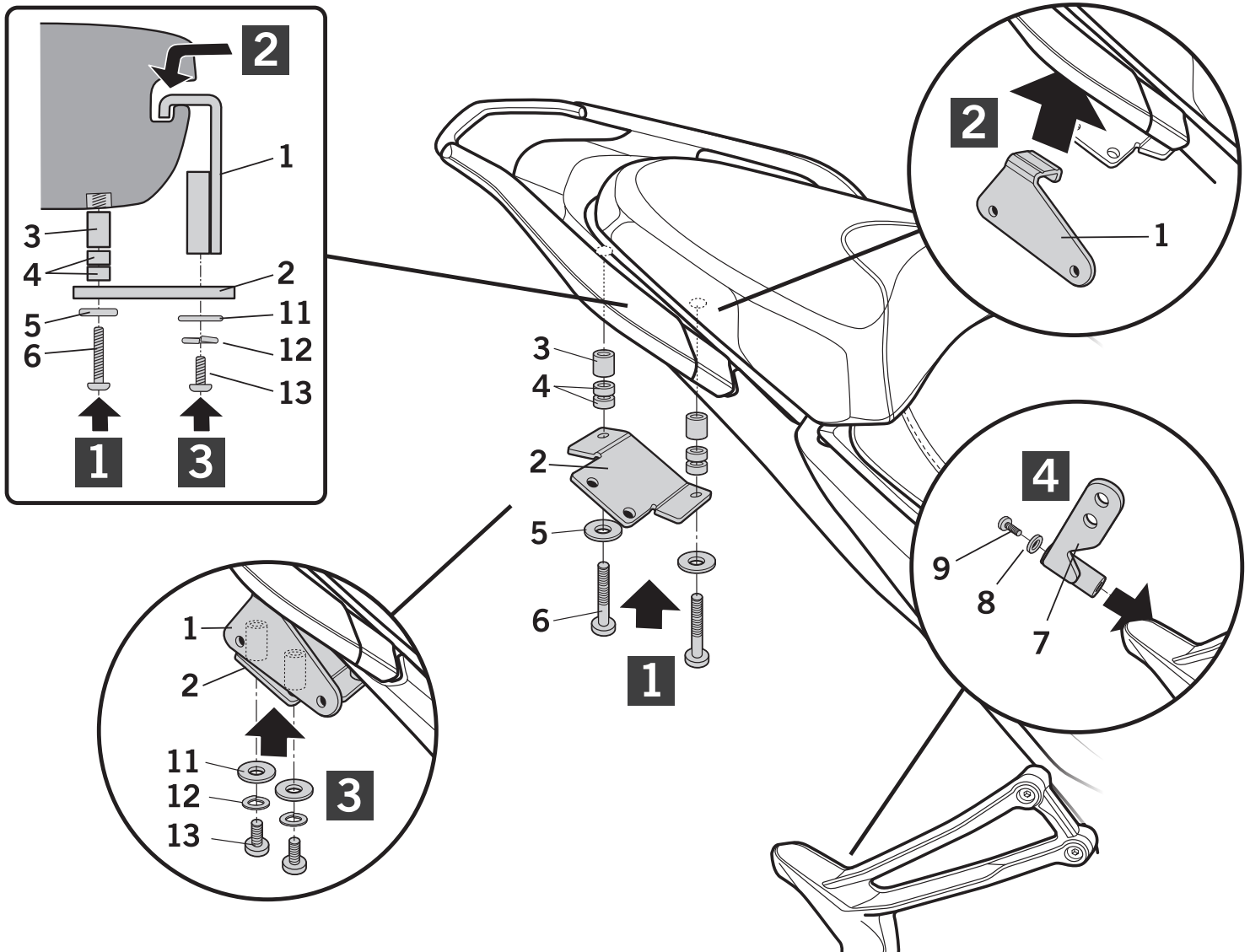

IMPORTANT: Based on European models. For compatibility with models in other continents, check www.shad.es

SHAD

DUCATI MULTISTRADA
950/950S/1200/1260 '16-'21
DOML98IF

3P
SYSTEM

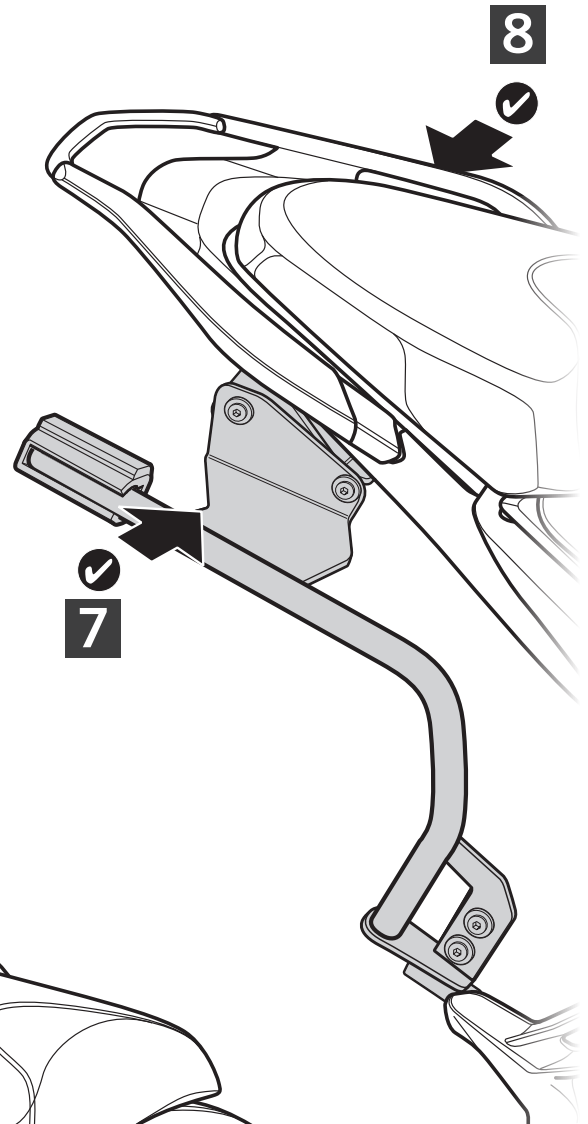
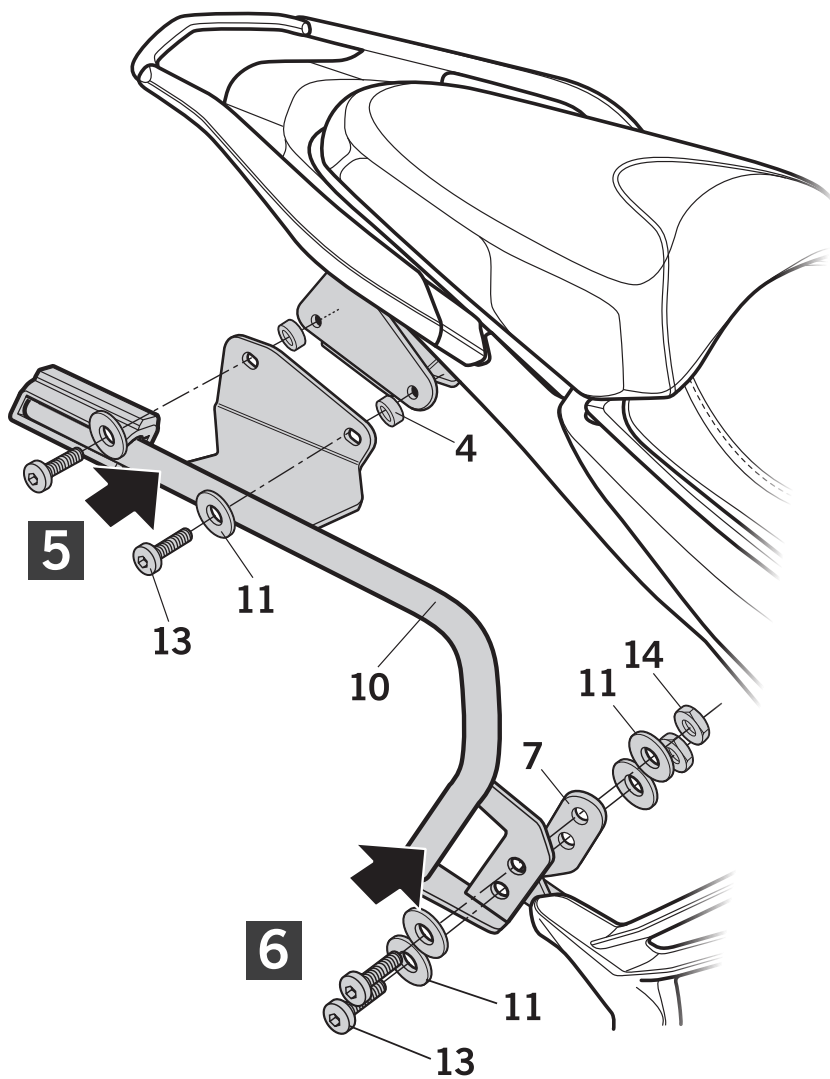

TOP MASTER
+
3P SYSTEM

